

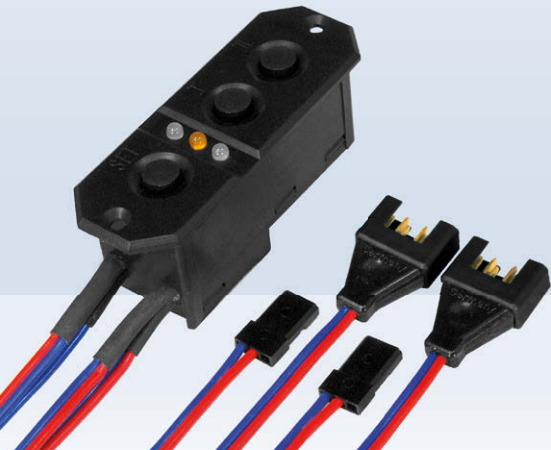

PowerBox Systems®

*World Leaders in RC
Power Supply Systems*

SENSOR



Dear customer,

we are delighted that you have decided to purchase the **PowerBox Sensor** power supply from our range.

We hope you have many hours of pleasure and great success with your **Power-Box Sensor**.

Product description

The **PowerBox Sensor** provides genuine redundancy in the power supply system, and is in no way inferior to its big brothers in terms of security, as it features two integral, completely independent regulatory and switching systems. Other comparable products available commercially boast of duplication, but this always simply refers to the number of batteries connected to the system. Our backer is actually fitted with two micro-controllers, two regulatory circuits, two switch circuits and a dual voltage monitoring circuit.

In order to be able to use modern battery types such as LiPo/Lilon and LiFePo, the two integral regulators reduce the battery voltage to 5.9 V, which is the correct value for 6 V servos. The unit is also a good choice for capping the voltage of 5S NiMH packs at 5.9 V, as the voltage of these batteries can be excessive when fully charged. Regulating the voltage extends the useful life of the servos, and ensures constant servo torque and transit speed - regardless of the state of charge of the batteries.

Two tri-colour LEDs indicate the state of charge of the batteries in four stages. The **PowerBox** also includes a minimum voltage memory which stores the lowest

voltage value which occurs during a flight, enabling the pilot to monitor his batteries more accurately. After the flight the minimum value can be read from the LEDs by pressing buttons I and II.

FEATURES

- double-regulated output voltages for receivers and servos
- 5.9V output voltage
- Separate voltage display for each battery
- Minimum value memory alerts the user to voltage collapses
- Support for four battery types: LiPo, Lilon, NiMH / NiCd, LiFePo
- Suppression of any servo feedback currents which may occur

CONTENT

| | |
|---|----|
| 1. Lay-out and connections..... | 4 |
| 2. Mounting and connecting the batteries..... | 4 |
| 3. Switching On and Off | 5 |
| 4. Setting the battery indicator | 6 |
| 5. Maximum power capacity..... | 7 |
| 6. Specification..... | 8 |
| 7. Dimensions | 8 |
| 8. Set contents | 9 |
| 9. Service note..... | 9 |
| 10. Guarantee conditions..... | 10 |
| 11. Liability exclusion..... | 11 |

1. LAY-OUT AND CONNECTIONS

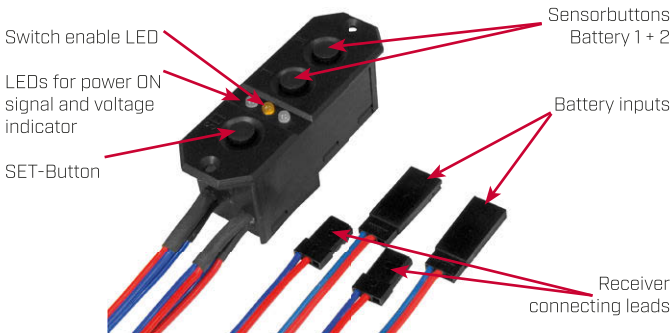

2. MOUNTING AND CONNECTING THE BATTERIES

The internal card packaging can be used as a template for installing the **PowerBox Sensor**. The **PowerBox Sensor** should also be installed at a point where vibration is low. The GRP fuselage sides of a powered model aircraft are not suitable for this, as they suffer from severe vibration. The appropriate area should be stiffened with a piece of plywood 2 to 3 mm thick; 20 to 40 mm of wood round the switch is generally sufficient to stiffen the GRP fuselage side. Gluing the plate to the GRP material helps to absorb the vibration, and also provides plenty of “meat” for the switch retaining screws.

Connect a battery of your choice to the battery input, taking care to maintain correct polarity. This can be a 2S (7.4 V) LiPo/Lilon, a 5S NiCd / NiMH battery, or a 2S (6.6 V) LiFePo pack.

By default the voltage monitor is set up to work with a LiPo/Lilon battery.

We recommend that you use the LiPo/Lilon or LiFePo battery packs which we manufacture. All **PowerBox batteries** are equipped with appropriate electronic monitor and security circuits, balancer and integral charger. All our batteries are supplied complete with a practical mounting frame of the correct size.

Caution: connecting the battery with reversed polarity will instantly ruin the integral linear regulator!

3. SWITCHING ON AND OFF

Switching the unit on and off is very simple, and the process effectively prevents accidentally changing the **PowerBox's** status. This is the procedure:

Locate the SET button on the **PowerBox Sensor** and hold it pressed in until the central LED glows red. Now press buttons I and II in turn; the backer is now switched on.

Repeat the procedure to switch off: hold the SET button pressed in, wait until the central LED glows red, then confirm by pressing buttons I and II in turn.

Once switched on, the **PowerBox** can only be turned off again using the switches. Intermittent contacts or interruptions in the power supply cannot cause the **Power-Box** to be switched off permanently.

4. SETTING THE BATTERY INDICATOR

If you intend to use a 5S NiCd or NiMH battery, or a 2S LiFePo battery, you must set the voltage monitor correctly, otherwise the LED will constantly flash red. However, this setting has no influence at all on the actual switching process or the stabilising circuits.

This is the procedure for setting the various battery types:

- Connect both batteries, and switch on the **PowerBox Sensor**.
- Hold the SET-button pressed in, and observe the middle, red LED.
- The LED first light up red, then go out again after a few moments.
- Pause, keep the button pressed in.
- The LEDs flash red once. If you release the button now, the battery type “2S LiPo” is selected.
- Pause, keep the button pressed in.
- The LEDs flash red twice. If you release the button now, the battery type “5S NiMH” is selected.
- Pause, keep the button pressed in.
- The LEDs flash red three times. If you release the button now, the battery type “2S LiFePo” is selected.

This procedure does take a few seconds, but it is designed to eliminate the risk of changing the setting accidentally. In any case, it only has to be carried out if you switch to a different battery type. The setting is stored permanently in the two micro-controllers.

5. MAXIMUM POWER CAPACITY

The maximum capacity of the **PowerBox Sensor** is stated in the specification (3 to 5A), but please note that this does not refer to the maximum performance of the **PowerBox Sensor**'s voltage regulator, as it varies according to the efficiency of the cooling measures. To achieve good cooling (and therefore high performance) we have fitted a blue anodized heat-sink on the back of the **PowerBox Sensor**. The heat-sink is recessed into the switch case to ensure that this component cannot be completely covered even if the switch is not mounted in an unfavourable position.

Please ensure that waste heat can be dissipated freely via this heat-sink.

The electronic components are designed for a maximum regulator capacity for at least 12 A. If this level is exceeded, the **PowerBox Sensor** does not switch itself off.

The same applies if the voltage of the batteries falls below 5.9 Volts; this also does not cause the **PowerBox Sensor** to switch itself off, the remaining voltage available is always passed through to the receiving system.

If you notice that the **PowerBox Sensor** becomes hot in use (above 60° Celsius), this is a reliable indication that the servos you are using are consuming a disproportionate amount of power. Please check your servos, pushrods, linkages etc. If the receiving system is in good condition, you can remedy the situation either by re-positioning the **PowerBox Sensor** in a location with a better air-flow, or by replacing the unit with a **PowerBox Gemini II** or **BaseLog**, which are designed for higher-current applications.

6. SPECIFICATION

| | |
|-------------------------------|--|
| Operating voltage: | 4.0V - 9.0V |
| Power supply: | 2S LiPo, 2S Lilon, 2S LiFePo, 5S NiCd/NiMH |
| Current drain Power-on state: | 30mA |
| Current drain Standby: | 5 μ A |
| Maximum load current: | Peak 2x4A |
| Drop-out voltage: | 0.3V |
| Output voltage: | 5.9V regulated |
| Dimensions: | 65 x 23 x 26 mm |
| Weight: | 35g |
| Temperature range: | -30°C to +75°C |

7. DIMENSIONS

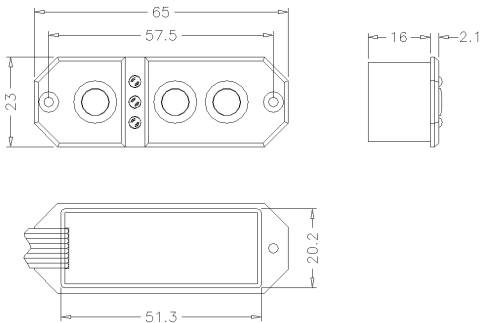

8. SET CONTENTS

- PowerBox Sensor
- Mounting screws
- Operating instructions in English and German

9. SERVICE NOTE

We are anxious to offer good service to our customers, and to this end we have set up a Support Forum which deals with all queries concerning our products. This relieves us of a great deal of work, as it eliminates the need to answer frequently asked questions time and again. At the same it gives you the opportunity to obtain help quickly all round the clock - even at weekends. All the answers are provided by the **PowerBox Team**, guaranteeing that the information is correct.

Please use the Support Forum before you telephone us.

You can find the forum at the following address:

www.forum.powerbox-systems.com

10. GUARANTEE CONDITIONS

At **PowerBox-Systems** we insist on the highest possible quality standards in the development and manufacture of our products. They are guaranteed **“Made in Germany”!**

That is why we are able to grant a **36 month guarantee** on our **PowerBox Sensor** from the initial date of purchase. The guarantee covers proven material faults, which will be corrected by us at no charge to you. As a precautionary measure, we are obliged to point out that we reserve the right to replace the unit if we deem the repair to be economically unviable.

Repairs which our Service department carries out for you do not extend the original guarantee period.

The guarantee does not cover damage caused by incorrect usage, e.g. reverse polarity, excessive vibration, excessive voltage, damp, fuel, and short-circuits. The same applies to defects due to severe wear.

We accept no liability for transit damage or loss of your shipment. If you wish to make a claim under guarantee, please send the device to the following address, together with proof of purchase and a description of the defect:

SERVICE ADDRESS

PowerBox-Systems GmbH
Ludwig-Auer-Straße 5
D-86609 Donauwoerth
Germany

11. LIABILITY EXCLUSION

We are not in a position to ensure that you observe our instructions regarding installation of the **PowerBox Sensor**, fulfil the recommended conditions when using the unit, or maintain the entire radio control system competently.

For this reason we deny liability for loss, damage or costs which arise due to the use or operation of the **PowerBox Sensor**, or which are connected with such use in any way. Regardless of the legal arguments employed, our obligation to pay compensation is limited to the invoice total of our products which were involved in the event, insofar as this is deemed legally permissible.

We wish you every success with your new **PowerBox Sensor**.

A handwritten signature in blue ink, appearing to be 'De AR', written in a cursive style.

Donauwoerth, March 2017

PowerBox-Systems GmbH

certificated according to DIN EN ISO 9001:2008

Ludwig-Auer-Straße 5
D-86609 Donauwoerth
Germany



+49-906-99 99 9-200



+49-906-22 45 9

www.powerbox-systems.com